

CLASSE

Owner's Manual
CA-D200
Two-Channel Amplifier

NOTICE

All of us at Classé take extreme care to ensure that your purchase will remain a prized investment. We are proud to inform you that all Classé components have been officially approved for the European Community (CE) mark.

This means that your Classé product was subjected to the most rigorous manufacturing and safety tests in the world. The CE mark certifies that your purchase meets or exceeds all European Community requirements for manufacturing consistency and consumer safety.

This equipment has been tested and found to comply with the limits for a Class B digital device, pursuant to Part 15 of the FCC Rules. Operation is subject to the following two conditions: (1) This device may not cause harmful interference, and (2) This device must accept any interference received, including interference that may cause undesired operation. These limits are designed to provide reasonable protection against harmful interference in a residential installation. This equipment generates, uses and can radiate radio frequency energy and, if not installed and used in accordance with the instructions, may cause harmful interference to radio communications. However, there is no guarantee that interference will not occur in a particular installation. If this equipment does cause interference to radio or television reception, which can be determined by turning the equipment on and off, the user is encouraged to try to correct the interference by one or more of the following measures:

- Reorient or relocate the receiving antenna;
- Increase the separation between the equipment and the receiver;
- Connect the equipment into an outlet on a circuit different from that to which the receiver is connected;
- Consult the dealer or an experienced radio/TV technician for help.

CAUTION: Changes or modifications to this equipment not expressly approved by the manufacturer could void the user's authority to operate the equipment.

The information contained in the manual is subject to change without notice. The most current version of this manual will be posted on our web site at <http://www.classeaudio.com>.



Classé marks the "CE" symbol indicating compliance of this device with the EMC (Electromagnetic Compatibility) and LVD (Low Voltage Directive) standards of the European Community.



Classé complies with the European Parliament and Council Directive 2002/96/EC concerning Waste Electrical and Electronic Equipment (WEEE). This product must be appropriately recycled or processed in accordance with these directives. Consult your local waste disposal authority for guidance.



Classé products are designed and manufactured to comply with the Restriction of Hazardous Substances (RoHS) as stated in the European Parliament and Council Directive 2002/95/EC.

Important Safety Instructions

1. Read these instructions.
2. Keep these instructions.
3. Heed all warnings.
4. Follow all instructions.
5. Do not use this apparatus near water.
6. Clean only with dry cloth.
7. Do not block any ventilation openings. Install in accordance with the manufacturer's instructions.
8. Do not install near any heat sources such as radiators, heat registers, stoves, or other apparatus that produce heat.
9. Do not defeat the safety purpose of the polarized or grounding-type plug. A polarized plug has two blades with one wider than the other. A grounding type plug has two blades and a third grounding prong. The wide blade or the third prong are provided for your safety. If the provided plug does not fit into your outlet, consult an electrician for replacement of the obsolete outlet.
10. Protect the power cord from being walked on or pinched particularly at plugs, convenience receptacles, and the point where they exit from the apparatus.
11. Only use attachments/accessories specified by the manufacturer.
12.  Use only with the cart, stand, tripod, bracket, or table specified by the manufacturer, or sold with the apparatus. When a cart is used, use caution when moving the cart/apparatus combination to avoid injury from tip-over.
13. Unplug this apparatus during lightning storms or when unused for long periods of time.
14. Refer all servicing to qualified service personnel. Servicing is required when the apparatus has been damaged in any way, such as power-supply cord or plug is damaged, liquid has been spilled or objects have fallen into the apparatus, the apparatus has been exposed to rain or moisture, does not operate normally, or has been dropped.
15. Do not expose this apparatus to dripping or splashing and ensure that no objects filled with liquids, such as vases, are placed on the apparatus.

**WARNING: TO REDUCE THE RISK OF FIRE OR ELECTRIC SHOCK,
DO NOT EXPOSE THIS APPLIANCE TO RAIN OR MOISTURE.**

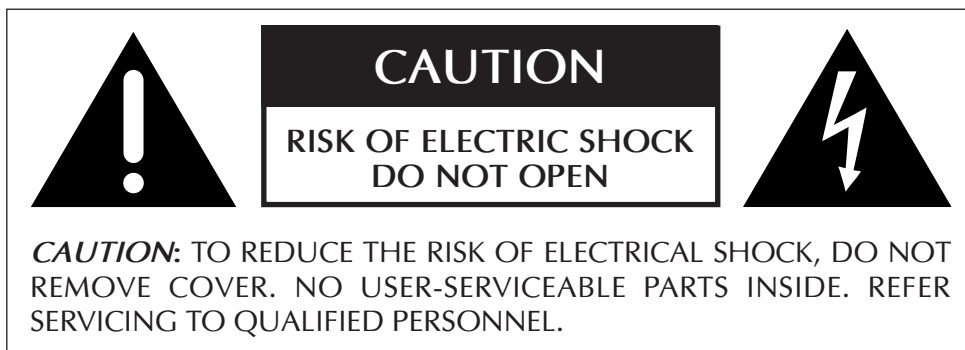

The lightning flash with arrowhead symbol within an equilateral triangle is intended to alert the user to the presence of uninsulated “dangerous voltage “ within the product’s enclosure that may be of sufficient magnitude to constitute a risk of electric shock to persons.



The exclamation point within an equilateral triangle is intended to alert the user to the presence of important operating and maintenance (servicing) instructions in the literature accompanying the product.

Contents

Welcome to the Classé family	5
a word about installation	5
Unpacking and Placement.....	6
unpacking your amplifier	6
placement.....	6
ventilation.....	6
custom installations	6
serial number	6
operating voltage	6
warm up/break-in period	7
please read this manual.....	7
Special Design Features	8
highly refined circuit design.....	8
extensive listening tests.....	8
extraordinary longevity	8
robust protection.....	8
Front Panel.....	9
Rear Panel.....	10
Installation	14
CAN-Bus.....	15
<i>features</i>	15
<i>hardware setup</i>	16
using CAN-Bus.....	18
CAN-Bus shared features	18
configuration.....	18
operate.....	18
AC status.....	19
status.....	19
name.....	19
global brightness.....	19
global standby	19
CAN-Bus model-specific features.....	19
PlayLink.....	19
amp info	20
event log.....	21
Care and Maintenance.....	22
Troubleshooting	23
Specifications.....	25
Dimensions.....	26

Welcome to the Classé family

Congratulations on your purchase of a Classé amplifier. It is the result of many years of design experience, and we are sure that you will enjoy it for many years to come.

We value our relationship with our customers. Please allow us to stay in touch with you by returning your warranty card now, before you pack up the shipping carton of your new product and forget all about it. Doing so will enable us to let you know about any possible future upgrades or updates that might become available for your Classé component.

You can register online at www.classeaudio.com or complete and mail the registration card located in the separate warranty booklet.

Please take a few moments now to register your new Classé amplifier and record your serial number for future reference

a word about installation

Every effort has been made to make the Classé CA-D200 simple and straightforward to install and use.

It may be placed on a shelf, in a cabinet or on the floor near the speaker(s). Although the CA-D200 is an extremely efficient design, as with all amplifiers, some heat is generated and care should be taken to allow adequate ventilation.

The size and shape of your room, its acoustics, and the associated equipment you have chosen to use with your amplifier all influence the performance of your system.

For this reason, we strongly encourage you to have your system installed and calibrated by your dealer, whose experience, training, and specialized equipment can make a profound difference in the final performance of the system.

Unpacking and Placement

unpacking your amplifier

Carefully unpack your power amplifier according to the supplied instructions, and remove all accessories from the carton. Please take care when lifting the amplifier, as it is heavier than it may appear.



Important!

Keep all packing materials for future transport of your Classé amplifier. Shipping your new component in anything other than its purpose-designed packing material may result in damage that is not covered by the warranty.

placement

Many installations will utilize an equipment rack, although a shelf, a cabinet or the floor near the speaker(s) are acceptable alternatives. In any case, take care to position it well away from source components and preamp/processors, which may be sensitive to the amplifier's electromagnetic fields.

Note that adequate clearance for the AC cord and connecting cables must be left behind the amplifier. We suggest leaving six inches (15 cm) of free space behind your power amplifier to allow all cables sufficient room to bend without crimping or undue strain.

ventilation

Your Classé power amplifier generates a certain amount of heat in the course of normal operation. Avoid placement on soft surfaces that would restrict airflow around the unit (such as plush carpeting).

custom installations

Drawings are included in this manual to facilitate special installations and custom cabinetry (see the section *Dimensions*). Contact your Classé dealer for more information.

serial number

The serial number for your power amplifier is found on the rear of the unit. Please note and record this number on the page entitled *Important Safety Instructions* for your future reference.

operating voltage

The operating voltage of your CA-D200 is 100-240 V, 50/60 Hz.



Warning:

There are no user-serviceable parts within the unit. Please refer any problems to an authorized Classé service center.

The amplifier can easily be powered by a normal 15 or 20-ampere AC mains line. If other devices are also powered from the same AC line, their additional power consumption should be taken into account.

warm up/break-in period

Your new Classé power amplifier will deliver outstanding performance immediately. However, you should expect to hear it improve somewhat as it reaches its normal operating temperatures and its various components “break-in.” It has been our experience that the greatest changes occur within the first 72 hours, as the amplifier reaches thermal equilibrium and the capacitors fully form. After this initial break-in period, the performance of your new amplifier should remain quite consistent for years to come.

please read this manual...

Please take a few minutes to review this manual, and to familiarize yourself with your new amplifier. We understand that you are anxious to plug everything in and get started. However, reading this manual and following the advice it gives will ensure that you get all the benefits you deserve from having purchased such a fine piece of equipment.

Special Design Features

highly refined circuit design

This Classé amplifier benefits from the use of high quality component parts, application of advanced class D amplifier design principles and exhaustive testing. To conquer one of the most challenging problems in class D design, a dead-band time minimization algorithm is initiated at turn-on to ensure the lowest possible distortion; consequently, less overall negative feedback is required for optimum performance. This unusual accomplishment showcases both the innovation of the design and the persistence of the Classé Design team.

extensive listening tests

Excellent measured performance is to be expected in world-class products, and Classé products deliver that performance. However, experience has shown that technical excellence alone is insufficient to guarantee subjectively musical results.

For this reason, all Classé products are laboriously fine-tuned during the development process by carefully controlled listening tests. Our ears are still some of the finest test instruments available, and nicely complement more traditional engineering test equipment. We rely on careful listening tests, which we view as a necessary complement to the solid engineering you should rightly expect from Classé.

extraordinary longevity

The Classé Design team has accumulated vast experience in what works well over the long term.

By using only the highest quality parts to begin with, and then using them in an informed way as a result of both accelerated aging tests and actual long-term experience, we are able to design and manufacture products which we are confident will stand the test of time.

We are confident that your new Classé amplifier will give you many years of trouble-free reliability and musical enjoyment, just as previous Classé products have given their owners.

robust protection

Finally, your new Classé amplifier incorporates a variety of protection circuits, all designed to protect both the amplifier and your loudspeakers against dangerous fault conditions. Significantly, these protection circuits do not intrude upon or limit the normal performance of the amplifier; rather, they simply put the amplifier into *protection* mode when confronted with abnormal conditions. These conditions include:

- output overload and short circuit protection
- DC offset
- excessive operating temperatures

Some conditions, such as DC offset, are corrected automatically in the amplifier while others will result in either the amplifier temporarily reducing its output or, in extreme cases, switching itself off. In such a case, the **Standby LED** status indicator will blink red until the fault can be righted and the amplifier is reset by pressing and holding the standby button for at least three seconds.

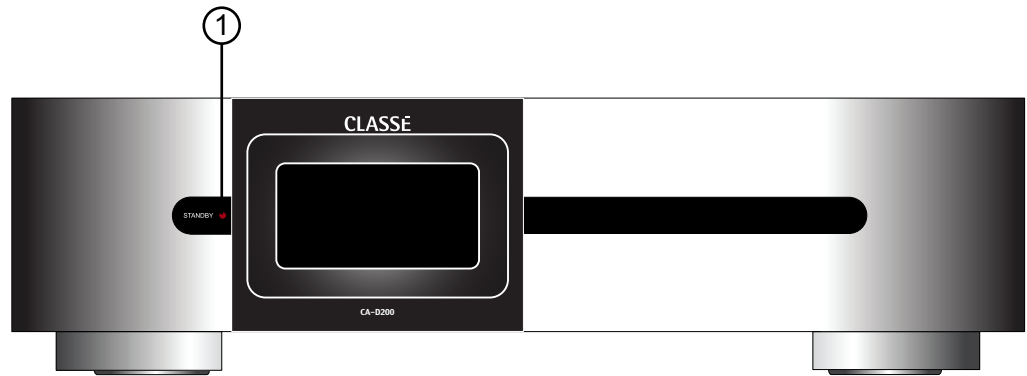

Front Panel

1 Standby button & LED status indicator

The front panel **Standby** button will toggle the amplifier between operate, its fully operational state, and a *standby* mode that leaves the amplifier off, yet ready to respond to system commands via any of the supported control options (e.g. IR input, DC trigger, CAN-Bus, or RS-232).

The current state of the amplifier is indicated by the **LED** status indicator in the **Standby** button. The state of this **LED** indicates the following:

- on (red) = *standby*
- flashing (blue) = *initialization*
- on (blue) = *operate*
- slow flashing (red) = *protection circuit(s) engaged*

When in *standby*, the amplifier's gain stages are powered down. Only a small power supply and control circuit remain on, consuming relatively little power. Fortunately, since the output stages by their nature conduct a great deal of current, they warm up and sound their best very quickly.

If you are not going to use the amplifier for an extended period of time, we suggest you disconnect it from the AC mains.

Also, it is a good practice to physically disconnect any and all valuable electronics from the AC mains during electrical storms, as a lightning strike anywhere near your home can put a tremendous surge on the AC mains that can easily damage any piece of electronics, no matter how well designed and protected. The best protection in the case of severe electrical storms is to simply remove the electronics from any connection with the power grid.



Caution!

If you see the Standby LED indicator blinking red, please check that all external connections are cleanly made and secure. If no fault is immediately obvious, try to reset the amplifier by pressing and holding the standby button. If the unit does not reset or continues to enter protection mode, please call your authorized Classé dealer for assistance.

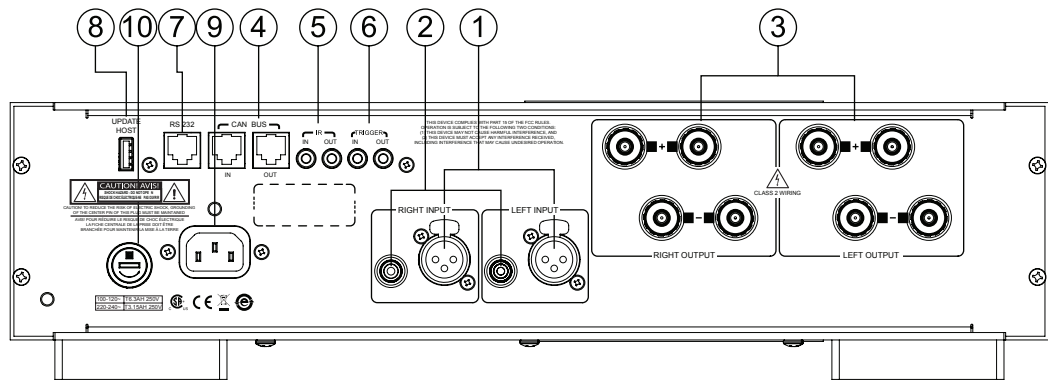

Rear Panel

The following descriptions are intended as a quick reference, should you have any questions about your new product. Please see the next section (*entitled Initial Setup*) for specific advice on incorporating your new amplifier into your system.

1 Balanced (XLR) Input

Balanced audio interconnections were originally developed for the telephone and more recently have been used in the professional audio world for preserving the delicate nuances of extremely small microphone-level signals. For many years now, they have also been used by performance-oriented companies such as Classé to preserve every nuance of the finest audio recordings in your collection.

Technically, balanced audio interconnections provide two distinct benefits: they double the signal's strength as it travels from one component to the next, increasing the potential Signal-to-Noise ratio by 6 dB; they also do an excellent job of rejecting noise and interference that might otherwise be picked up between the components. If executed with a high degree of symmetry between the inverting and non-inverting signal paths, balanced connections can offer the best performance. For this reason, we strongly recommend using the balanced analog interconnections between your Classé components wherever possible.

The pin assignments of these **XLR input connectors** are:

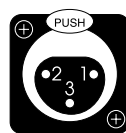

Pin 1: Signal ground

Pin 2: Signal + (non-inverting)

Pin 3: Signal – (inverting)

Connector ground lug: chassis ground

These pin assignments are consistent with the standard adopted by the Audio Engineering Society (AES14-1992).

If you are using your Classé power amplifier with a Classé preamplifier/processor, you're all set – just remove the supplied shorting pins (between Pins 1 and 3) from the amplifier's XLR connector(s), take standard balanced interconnect cables and plug them in.

If you are using another brand of preamplifier or processor, please refer to its operating manual to verify that the pin assignments of its output connectors correspond to those of your amplifier. If not, have your dealer obtain cables with the appropriate output pin connecting to the equivalent input pin.

2 Single-Ended (RCA) Input

Single-ended cables using **RCA** connectors are the most common form of analog connection used in consumer electronics. When implemented carefully and with use of high quality interconnecting cables, this standard can provide excellent performance. Classé has gone to extraordinary effort to ensure that the single-ended (RCA) input of your power amplifier is as good as possible. However, this connection standard cannot offer the immunity from interference that balanced interconnection does—hence our recommendation to use the balanced inputs when possible.

3 Speaker Outputs

Two pairs of high quality **five-way binding posts** are provided on the amplifier, in order to facilitate bi-wiring.

In practice, bi-wiring involves connecting two (preferably identical) sets of speaker cables between each amplifier channel and its corresponding loudspeaker. In many cases, the benefit is a subjectively improved level of clarity and detail from the speaker, as a result of being able to feed the two separate sections of its crossover and driver complement with identical, yet separate signals.

(Many high quality loudspeakers also offer two sets of connections on their speakers. Generally, one set of the connections on the loudspeaker feeds the portion of the speaker's crossover network that supplies the woofer with its signal; the other set of connections connects to the portion of the crossover that supplies the rest of the speaker with the midrange and high frequencies.)

Although the binding posts on your Classé amplifier will accept bare wire connections, we strongly recommend the use of high quality spade or hook lugs, crimped onto the ends of your speaker wires. Using high quality connectors will ensure that your speaker connections do not gradually deteriorate from fraying and oxidizing bare wires. It also helps prevent accidental short-circuits from poorly-terminated connections.

4 Classé CAN-Bus Control Ports

These **RJ-45** connectors are reserved for control and communication applications using a Classé implementation of the Controller Area Network (CAN) Bus specification. Refer to the **CAN-Bus** section located later in this manual for more information.

5 IR Input and Output

Your Classé amplifier includes two 1/8th-inch **mini mono-jacks** in order to support the IR remote controls that are ubiquitous today. IR commands exist for toggling the amplifier between *operate* and *standby*, as well as discrete command codes for either *operate* or *standby*. These codes may be used in “macros” for sophisticated remote control systems, facilitating the control of the amplifier in the larger context of a complete system.

Actually, this *IR Input and Output* description is a bit of a misnomer: the input supplied to these plugs is *electrical* in nature, not IR. It is obtained by using standard IR receivers, distribution amplifiers, and emitters (available from your dealer) to translate the remote's flashes of infrared light into corresponding pulses of electricity. The big advantages here include being able to easily route the signals anywhere they might need to go, and the reliability of a solid electrical connection.

Since an IR distribution system such as your dealer may design for you usually must control many products, your amplifier includes both an IR input (for the control of this product) and an IR output (so as to pass along the same signal to the next product). This allows you to “daisy chain” your control wires from one product to the next.

The amplifier is designed to respond to IR commands of 5 Volts DC, with the tip of the mini-plugs defined to be “positive” relative to the shank of the plug.



6 DC Trigger Input and Output

Many audio/video preamplifiers can supply a DC control voltage to associated equipment in order to induce desired behavior. Your Classé amplifier can take advantage of these capabilities in order to be switched between *operate* and *standby* automatically, perhaps in concert with the preamp/processor itself.

Two 1/8th-inch **mini mono-jacks** provide this remote-controlled turn-on (that is, toggling between *operate* and *standby*) of the amplifier. These jacks provide a simple pass-through of the control voltage from one to the other, allowing you to “daisy-chain” a series of amplifiers quite easily.

The remote trigger will be operated by the presence of 5–12 Volts DC, with tip polarity as shown below:

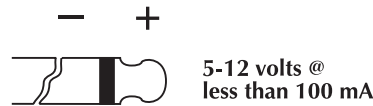

7 RS 232 Control Port

This **RJ-45 connector** is used for external RS-232 control of your amplifier by systems such as AMX[®], Crestron[™] and Control 4[™].

For more information, please contact your dealer and ask about home automation systems.

RJ-45 - DB9 female adaptor

If your RS-232 control system uses a cable with a male DB9 connector, you will need to buy or build an adaptor to convert the RJ-45 female to a DB9 female. Standard RJ45-to-DB9 female connectors come with RJ-45 pins and colors as below. Wire the DB9 adaptor according to this diagram and table.

RJ-45

Pin-1 = Blue
Pin-2 = Orange
Pin-3 = Black
Pin-4 = Red
Pin-5 = Green
Pin-6 = Yellow
Pin-7 = Brown
Pin-8 = White

DB9

Pin-1 = Brown
Pin-2 = Green
Pin-3 = Yellow
Pin-4 = Orange
Pin-5 = Red
Pin-6 = Blue
Pin-7 = NC
Pin-8 = Black
Pin-9 = White

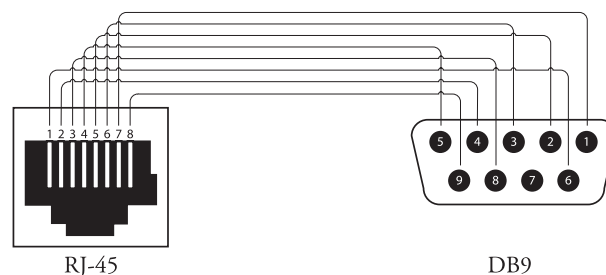

Remarks: The Cat 5 cable and connector that is used for the adaptor and plugs into the rear panel RJ-45 port must use pin-to-pin wiring.

8 USB Port

The USB connector is used to host a USB stick for updating amplifier firmware, should that become necessary.

9 AC Mains Input

An IEC standard power cord (supplied) is used with the CA-D200. Plug the cord into the **IEC receptacle** on the rear panel, and the other end into a suitable wall outlet.

10 AC Mains Fuse

Your Classé power amplifier has an **AC mains fuse**, accessible on the rear panel. If you suspect that your AC fuse has blown, disconnect your amplifier from the AC mains, as well as from its input connections and speaker connections, and refer to the appropriate item of the section entitled *Troubleshooting*.

Do not open your amplifier. There are no user-serviceable parts within this product.



Danger!

Potentially dangerous voltages and current capabilities exist within your power amplifier, even when disconnected from AC mains. Do not attempt to open any portion of the amplifier's cabinet. There are no user-serviceable parts inside your power amplifier. All service of this product must be referred to a qualified Classé dealer or distributor.

Installation

Your new Classé amplifier is quite simple to set up and enjoy. Please follow the steps outlined below in order to safely set up and use your new amplifier.



Important:

The AC mains connection should be the last connection you make on your new power amplifier. In addition, it is always a good idea to power up your power amplifier(s) last, after everything else has been powered up and has stabilized.

Conversely, it is good practice to power the amplifier(s) down first when shutting down the system, as this prevents any transients from other components from getting through to your loudspeakers.

- 1. Unpack everything according to the included instructions.**
Be careful when doing so, as this amplifier is heavier than it appears.
- 2. Place your amplifier (be sure to read “Unpacking and Placement”) and connect it to the AC mains.** This includes deciding on the location, making sure you have adequate ventilation, and adequate clearance for all the wires behind the amplifier. Once accomplished, connect the amplifier directly to the AC mains. Do not use extension cords, as most are not suitable for the current sometimes required by your amplifier.
- 3. Configure your amplifier turn-on delay/amp number.**
In a system that contains multiple Classé amplifiers, you may set the number of seconds of turn-on delay for each amplifier, allowing each to turn on in the order you have specified, rather than all at once. *This number also acts as an ID when using the CAN-Bus. (Having several powerful amplifiers all turning on at the same time can sometimes stress the AC mains in your home, potentially leading to nuisance tripping of circuit breakers).*

The amplifier sequence number (turn-on delay) may be programmed by your Classé dealer using a PC utility.

- 4. Make your preamp/processor connections.**
With the amplifier in *standby* (or disconnected from the AC mains), using high quality interconnecting cables, make the appropriate connections with the balanced or single-ended connectors.

Make sure all the connections are snug, even if it means gently squeezing the outer shell of the RCA with pliers and reinserting it to tighten the connection.

5. Make your speaker connections.

Make the connection between the output terminals of the amplifier and your loudspeakers, using high quality speaker wires.

Connect the black (–) terminals on the amplifier to the black (–) terminals on your speaker, and the red (+) terminals on the amplifier to the red (+) terminals on your speaker. If bi-wiring, run a total of four conductors between each amplifier channel and its corresponding loudspeaker: two separate +/- leads, one for the bass and the other for the mids and treble. Make sure that no wires cross between the red (+) and black (–) terminals, at either end.

Make sure all the connections are snug and cannot be easily wiggled free, but do not overtighten them. If you can give the speaker wires a reasonable tug without movement, they are snug. Further tightening will not make a better connection, and (taken to the extreme) may damage the connectors.

6. Double-check all your connections.

We understand that this step sounds redundant, but it is worth the extra minute or two it might take just to ensure that all connections are correct and secure before plugging the power cables to the AC outlets.

7. Turn on all the other components in your system, and then turn on your amplifier.

It is always good practice to turn any power amplifier on last, and to turn it off first. Doing so prevents any turn-on/turn-off transients that might originate in other components from damaging your loudspeakers.

CAN-Bus

Classé's Controller Area Network, or CAN-Bus, opens the way to a new level of interaction between similarly featured Classé components. When the amplifier is connected with other CAN-Bus-equipped Classé components, the different elements in the system are in constant communication, creating a "global" network that delivers system wide status information and shared operational features, all through the preamp/processor's touchscreen display.

Note that some CAN-Bus related features are initially not available for the CA-D200 and some components will require a software update to recognize the CA-D200 on the CAN-Bus. Check the Classé website periodically for updates.

features

CAN-Bus will allow a Classé touchscreen to:

- Display status information for every connected unit, including amplifiers which do not have a touchscreen display.
- Create a "PlayLink" that allows an SSP or Preamp to automatically switch to the correct input when a Delta series source component starts playback.
- Adjust the global system brightness.
- Configure the entire system to go in and out of standby at the touch of a button and also bring individual components in and out of standby.
- Mute any connected unit.

1 Classé CAN-Bus Equipped Products

Two or more Classé CAN-Bus equipped products are required, at least one of which must have a touchscreen display.

2 Category 5 Network Cables

These are ordinary network cables, commonly used for broadband Internet connections. They should be typical “straight through” cables not the “crossed over” type, and the total required will be one less than the total number of CAN-Bus equipped components in your system.

3 CAN-Bus Terminator

A single CAN-Bus Terminator may be required. It is inserted into the CAN-Bus OUT connector of the last component in the CAN-Bus daisy chain. One is included in the box with your amplifier. They are also available free of charge from your nearest Classé Customer Support Centre. <http://www.Classeaudio.com/support/service.htm>

4 SSP-300 & 600 CAN-Bus Interface Box

Systems that include an SSP-600 or SSP-300 will also require an SSP-300/600 CAN-Bus Interface Box. These are included with the products or available free of charge from your nearest Classé Customer Support Centre. <http://www.Classeaudio.com/support/service.htm>

The diagrams below illustrate how to connect the CAN-Bus hardware.

Any combination of models in any order.

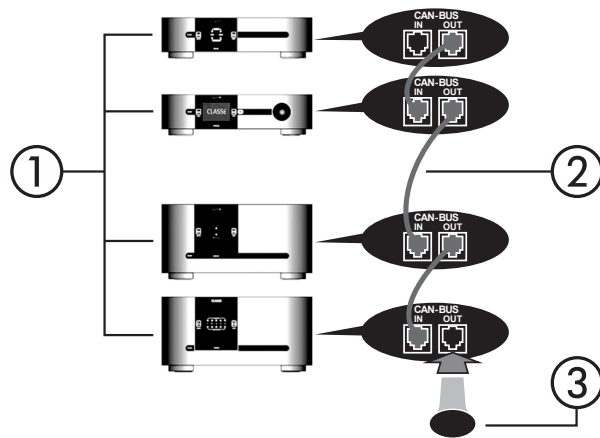

For any system **with** SSP-300 or SSP-600.

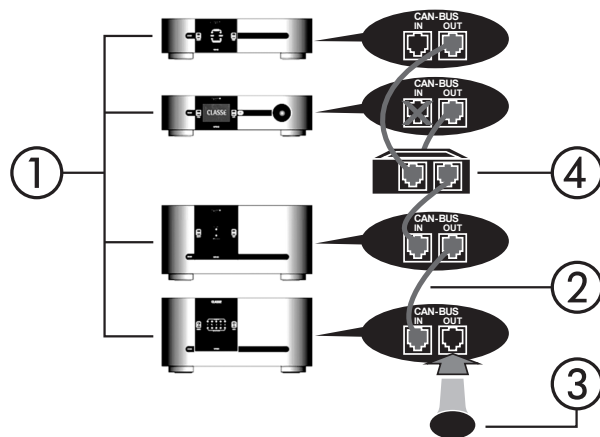

NOTE: Daisy chain may need to be terminated with CAN-Bus Terminator.

using CAN-Bus

CAN-Bus is controlled via the touchscreen of any Classé component that is so equipped. There is no master component, so Classé series systems where two or more units have a touchscreen can be controlled through any of the touchscreens. However, it is probably easiest to start using CAN-Bus through just one.

CAN-Bus is accessed by pressing the **menu** button on the face of the unit or remote, then the **status** button, followed by the **more** button.

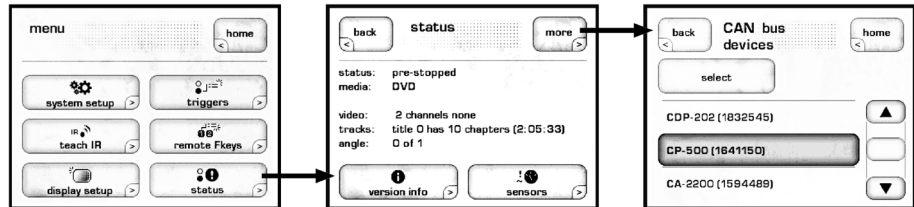

The touchscreen will then display the **CAN-Bus devices** screen, which lists connected components by model & serial number.

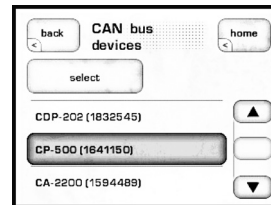

Highlighting a unit on the CAN-Bus devices screen identifies it as the **target unit**. The front panel LEDs of the target unit will start flashing (unless you highlight the unit that you are using to access CAN-Bus).

Once you have chosen the target unit press **select**. The target unit's LEDs will stop flashing and the touch screen will list the CAN-Bus features available to it. Some CAN-Bus features are shared by all models, some are specific to individual models.

CAN-Bus shared features

The following CAN-Bus features are shared by all models.

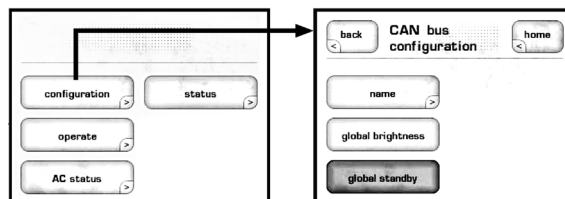

configuration

Selecting **configuration** will present the **CAN-Bus configuration** screen allowing access to name, global brightness, and global standby features.

operate

The **operate** settings allow you to bring the target unit in and out of standby, or mute. This key will be disabled for the unit whose touchscreen you are using to access CAN-Bus.

AC status The **AC status** screen displays information from the target unit's electrical supply sensors. Two screens are available, the second can be accessed by selecting **more**.

status The **status** screen is the simplest way to access essential information about the target unit. It displays the target unit's model number, software version, operational status and serial number.

name You can set the **name** that this component will be listed under in the CAN-Bus devices screen. The name will appear next to the unit model and serial number, and facilitate the identification of units in large systems.

global brightness By setting all your components to **global brightness** you can adjust the touchscreen and LED brightness for your entire system by changing the brightness of a single touchscreen. All CAN-Bus software updates automatically set the updated unit to Global Brightness. If you want a particular unit to be excluded from Global Brightness, deselect Global Brightness for that unit.

global standby By setting all your components to **global standby** you can bring your entire system in and out of standby by pressing the **standby** button of any unit or remote. All CAN-Bus software updates automatically set the updated unit to global standby. If you want a particular unit to be excluded from global standby, deselect global standby for that unit.

CAN-Bus model-specific features

The following CAN-Bus features are model specific.

PlayLink This feature is exclusive to Delta series disc players and will only function if the disc player is connected to a CAN-Bus enabled preamp or surround sound processor.

When **PlayLink** is active, pressing **play** on the disc player will also automatically switch the preamp/processor to a specified input. This means that you can listen to a CD or watch a DVD literally at the touch of a button.

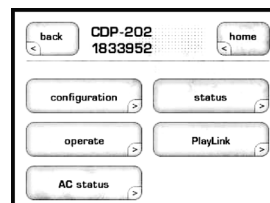

The first step in using PlayLink is to choose the **input** you wish to be selected when play is pressed on the disc player. Press the **PlayLink** icon, then select the correct input from the list.

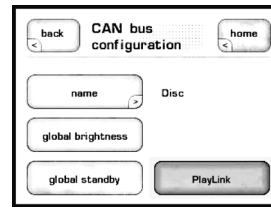

Once you have selected the input, press **back**, then select **configuration**. PlayLink is activated and disabled through the PlayLink icon on the CAN-Bus configuration screen.

PlayLink is automatically active after a software update, and the PlayLink icon will only appear on the CAN-Bus configuration screen of a Delta series disc player.

PlayLink can only select a single input per disc player. It is therefore not designed for users who regularly play both CDs and DVDs through different inputs from a single disc player. When PlayLink is active the disc player will default to the same input every time play is pressed, regardless of whether it is playing CD or DVD.

amp info

Available for amplifiers only, this screen displays the data provided by the heatsink and AC Module temperature sensors.

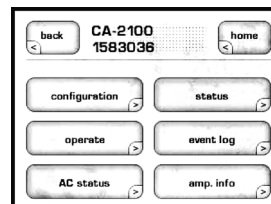

NOTE: This feature is only accessible when the target amplifier is on.

event log

Reserved for amplifiers, this feature is a protection circuitry **event log** which can only be accessed when the target amplifier is in **standby**. The protection circuit shuts down the amplifier or channel if it overheats or if its output could damage your speakers. The event log details the circumstances surrounding the amp going into protection and should be referred to in situations that require the intervention of your dealer or Classé customer support.

The log can report the following events interpreted as follows:

- **+ve slow blo trip & -ve slow blo trip** — The average current has reached the safe operating limit.
- **+ve fast blo trip & -ve fast blo trip** — The peak current has reached the safe operating limit.
- **over temperature trip** — The unit temperature has reached the safe operating limit.
- **DC Output trip** — The DC output level has reached the safe operating limit.
- **Communication failure** — There has been a loss of communication between the amp's system monitoring sensors.
- **AC line trip** — (Does not apply to CA-D200) The power supply has reached the limits of the amp's safe operating range.
- **Air intake filter** — (Does not apply to CA-D200) The intake filter is constricting airflow and should be cleaned. This "event" is also triggered after every 2,000 hours of operation, even if the sensors do not yet detect constricted airflow. The unit will continue to operate with its standby LED flashing until the filter is checked and the unit reset by pressing and holding the standby button for 3 seconds.

Events are rare and generally occur due to issues that are external to the amp. They should be interpreted positively. The amp is doing what it's designed to do.

Care and Maintenance

To remove dust from the cabinet of your amplifier, use a feather duster or a lint-free soft cloth. To remove dirt and fingerprints, we recommend isopropyl alcohol and a soft cloth. Dampen the cloth with alcohol first and then lightly clean the surface of the amplifier with the cloth. Do not use excessive amounts of alcohol that might drip off the cloth and into the amplifier.



Caution!

At no time should liquid cleaners be applied directly to the amplifier, as direct application of liquids may result in damage to electronic components within the unit.

Troubleshooting

In general, you should refer any service problems to your Classé dealer. Before contacting your dealer, however, check to see if the problem is listed here.

1. No sound, and Standby LED is not lit.

- The amplifier is not plugged into the AC mains, or the AC mains are down (circuit breaker, fuse).
- A brown-out or short-term loss of power might require the internal microprocessor to be reset. Unplug the unit for at least 30 seconds and then plug it in again and try powering it up.
- The AC mains fuse is blown. See *Troubleshooting #4*, below (or contact your Classé dealer).
- The AC mains is out of range. Check the line voltage supplying the amplifier.

2. No sound, and Standby LED is blinking red.

- The protection circuitry has been engaged.
- Press and hold the standby button to reset the amplifier.
- If the amplifier does not reset or continues to go into protection mode, disconnect the amplifier from the AC mains, and disconnect all inputs and outputs.
- Try to power up the amplifier again, connecting it only to AC power. If the LED continues to blink, there is a fault condition in the amplifier itself and it should be disconnected and taken to your Classé dealer for service.
- If it powers up without any difficulty, first power it back down and reconnect only the inputs, then restart the amplifier. If it again powers up normally, there may be a problem such as shorted speaker leads. Check the connections to confirm there are no obvious shorts, then connect first one channel, followed by the other, to confirm either that there is no longer a shorted lead or if there is, which channel is shorted.

3. The amplifier keeps shutting off.

- Make sure you are providing adequate ventilation to the amplifier and that the ambient room temperature is below 105°F (40°C).
- Run through the troubleshooting sequence outlined above (assuming the amplifier is going into its protection mode).
- The amplifier logs all protection circuit event--these are viewable on the touchscreen of a CAN-Bus connected Classé component or by your dealer on a PC using a special diagnostic program. Contact your dealer to assess the likely cause of the trouble.

4. The AC mains fuse is blown.

There is a specific troubleshooting procedure for a blown AC mains fuse, since this rare occurrence sometimes indicates a significant problem. Please use the following steps, in order:

- a. Disconnect your amplifier from the AC mains, as well as from its input connections and speaker connections, and remove the fuse cover on the rear of the unit.
- b. If the fuse appears to be blown, replace it only with a fuse of the same type and rating (specified below). *Using any other type of fuse, particularly a larger-value fuse, can result in permanent damage to your amplifier.* If you are not comfortable replacing the fuse yourself, contact your Classé dealer for assistance.

Mains voltage:	100-120VAC
Fuse type:	IEC time lag, high breaking capacity
Rating:	6.3AH 250V

Mains voltage:	200-240VAC
Fuse type:	IEC time lag, high breaking capacity
Rating:	3.15AH 250V

- c. After replacing the fuse and fuse cover, reconnect the amplifier to the AC mains only and turn it on *without reconnecting either the inputs or the speaker wires*. If the fuse blows again, disconnect it from the AC mains and contact your Classé dealer for assistance.
- d. If everything seems fine, place the amplifier back into standby and carefully reconnect the input cable and power up the amplifier. If the fuse then blows (or the amplifier goes into protection), you may have a serious fault with your preamplifier/processor. Contact your Classé dealer.
- e. Finally, if everything is still fine, place the amplifier in *standby* and carefully reconnect the speaker wires. Check *both* ends of the speaker wires for possible short circuits. Then power up the amplifier again. If the amplifier remains functional (the fuse does not blow), then the original fuse probably blew in order to protect the amplifier from a large AC mains surge. If it blows again, contact your Classé dealer for assistance.

Specifications

■ Frequency response	10Hz – 20kHz, -1dB into 4Ω
■ Output power	200W rms into 8Ω 400W rms into 4Ω
■ Harmonic distortion	<0.018% @ 1kHz Balanced Input
■ Peak Output Voltage	116V peak to peak, 58V rms no load 116V peak to peak, 58V rms into 8Ω
■ Input impedance	100kΩ Balanced / 50kΩ SE
■ Voltage gain	29 dB
■ Input level at clipping	1.4Vrms Balanced/SE
■ Intermodulation distortion	>80 dB below fundamental into 8Ω Balanced
■ Signal-to-Noise Ratio	-100 dB at peak output into 8Ω (AES17)
■ Standby power consumption	<1W @ 230V
■ Rated power consumption	177W @ 1/8th power into 4Ω
■ Mains voltage	90V - 264V, 50/60Hz
■ Overall Dimensions	Width: 17.50" (445mm) Depth (<i>excluding connectors</i>): 16.50" (419mm) Height: 4.78" (121mm)
■ Net weight	28.0 lbs (12.70 kg)
■ Shipping weight	37.0 lbs (16.30 kg)

All tests un-weighted and 20Hz – 20kHz measurement bandwidth used.

For more information, see your Classé dealer, or contact:

B&W Group Ltd.

5070 François Cusson

Lachine, Quebec

Canada H8T 1B3

Telephone +1 (514) 636-6384

FAX +1 (514) 636-1428

Internet: <http://www.classeaudio.com>

email: cservice@classeaudio.com

Classé and the Classé logo are trademarks of B&W Group Ltd., Worthing U.K. All rights reserved.

AMX® is a registered trademark of AMX Corporation of Richardson, TX. All rights reserved.

Crestron™ is a trademark of Crestron Electronics, Inc. of Rockleigh, NJ. All rights reserved.

Control 4™ is a trademark of Control 4 Corporation of Saltlake City UT. All rights reserved.

Dimensions

CA-D200

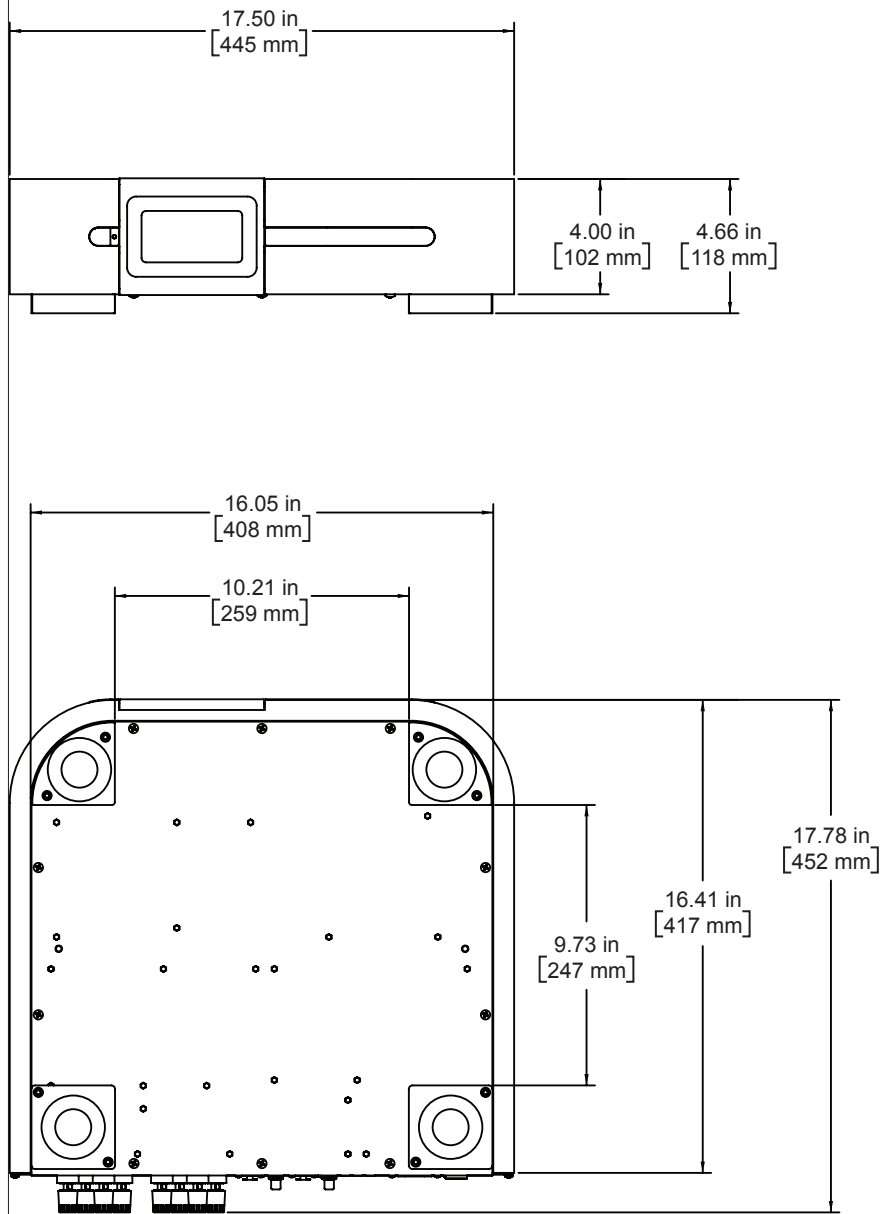

CLASSE

B&W Group Ltd.
5070 François Cusson
Lachine, Quebec
Canada H8T 1B3

+1 (514) 636-6384
+1 (514) 636-1428 (fax)

<http://www.classeaudio.com>

North America: (514) 636-6384
email: cservice@classeaudio.com

Europe: 44 (0) 1903 221 700
email: classe@bwgroup.com

Asia: (852) 2790 8903
email: classe@bwgroup.hk

All Others: +1 514 636 6384
email: cservice@classeaudio.com